

4

3

2

1

B

B

A

A

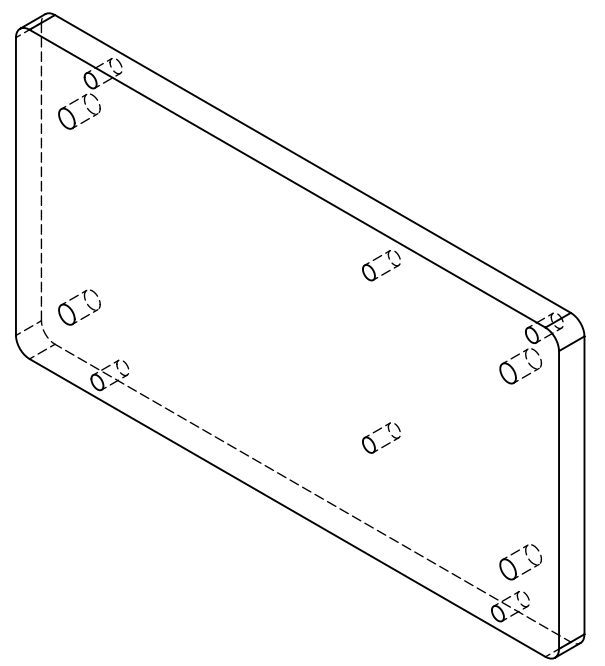
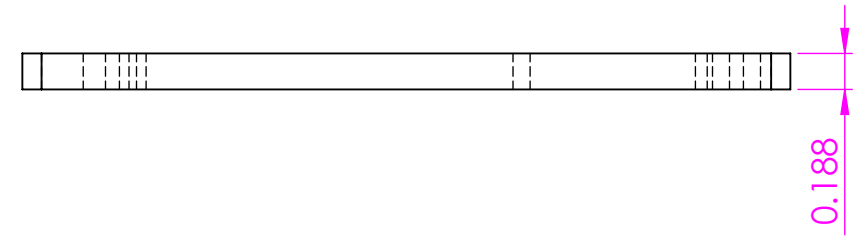
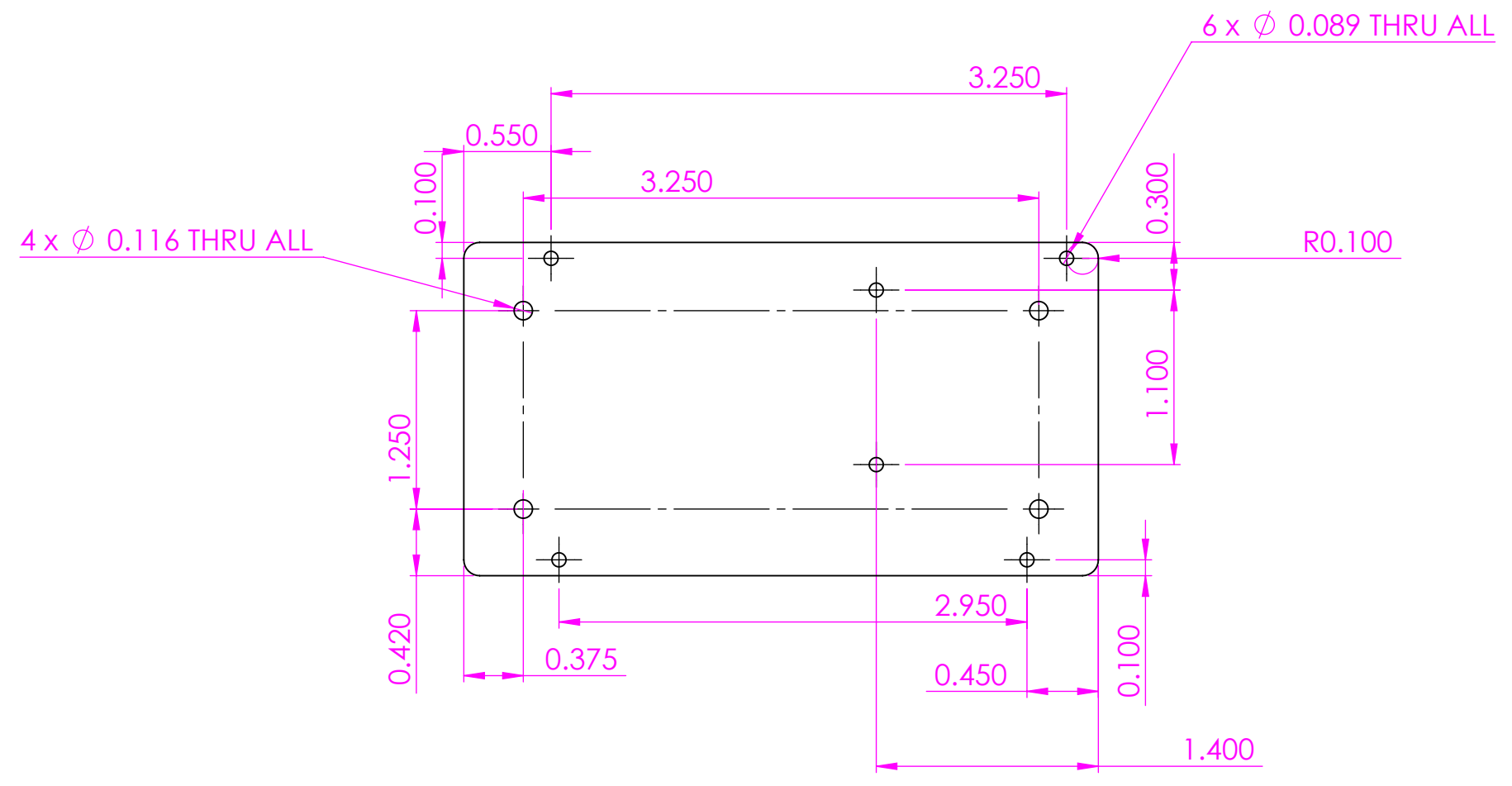

PROPRIETARY AND CONFIDENTIAL
 THE INFORMATION CONTAINED IN THIS
 DRAWING IS THE SOLE PROPERTY OF
 OPENAG, INC. ANY REPRODUCTION
 IN PART OR AS A WHOLE WITHOUT
 THE WRITTEN PERMISSION OF
 OPENAG, INC IS PROHIBITED.

		UNLESS OTHERWISE SPECIFIED:		NAME	DATE	tim savas	
		DIMENSIONS ARE IN INCHES TOLERANCES: ANGULAR: MACH ± 0.5 BEND ± 1 TWO PLACE DECIMAL ± 0.06 THREE PLACE DECIMAL ± 0.005		DRAWN		TITLE: arduino_mount	
		MATERIAL polycarbonate		CHECKED		SIZE B DWG. NO. REV 1	
		FINISH		ENG APPR.		SCALE: 1:1 WEIGHT: SHEET 1 OF 1	
NEXT ASSY	USED ON			MFG APPR.			
APPLICATION		DO NOT SCALE DRAWING		Q.A.			
				COMMENTS:			