

4

3

2

1

B

B

A

A

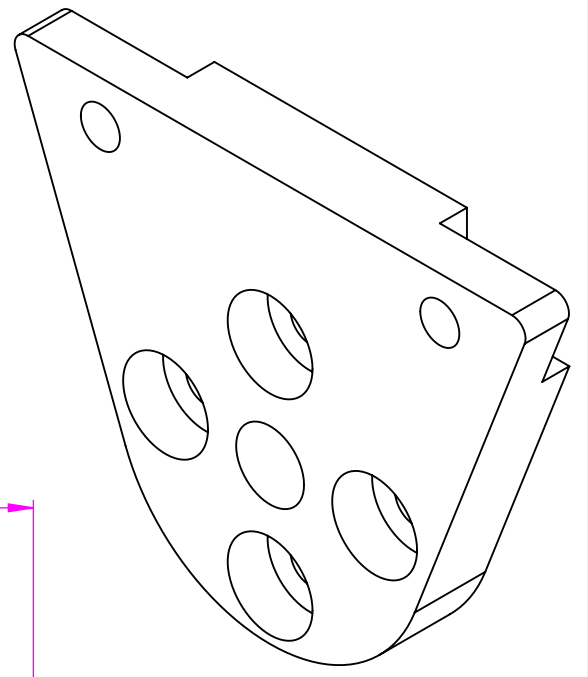
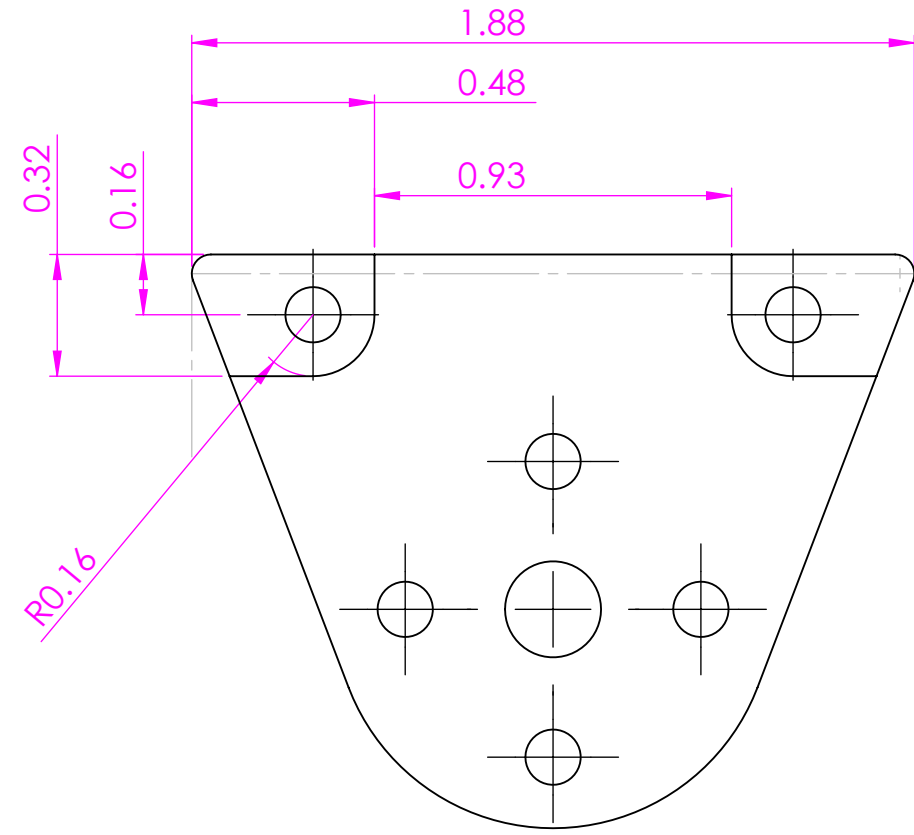
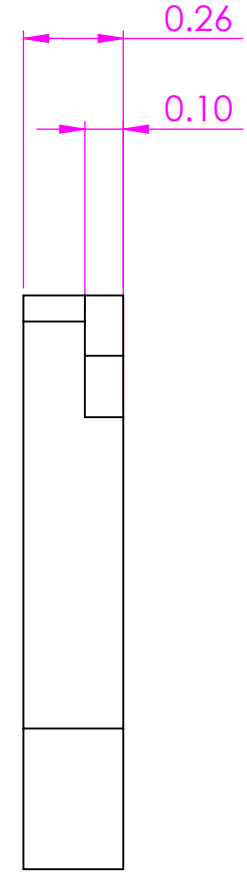
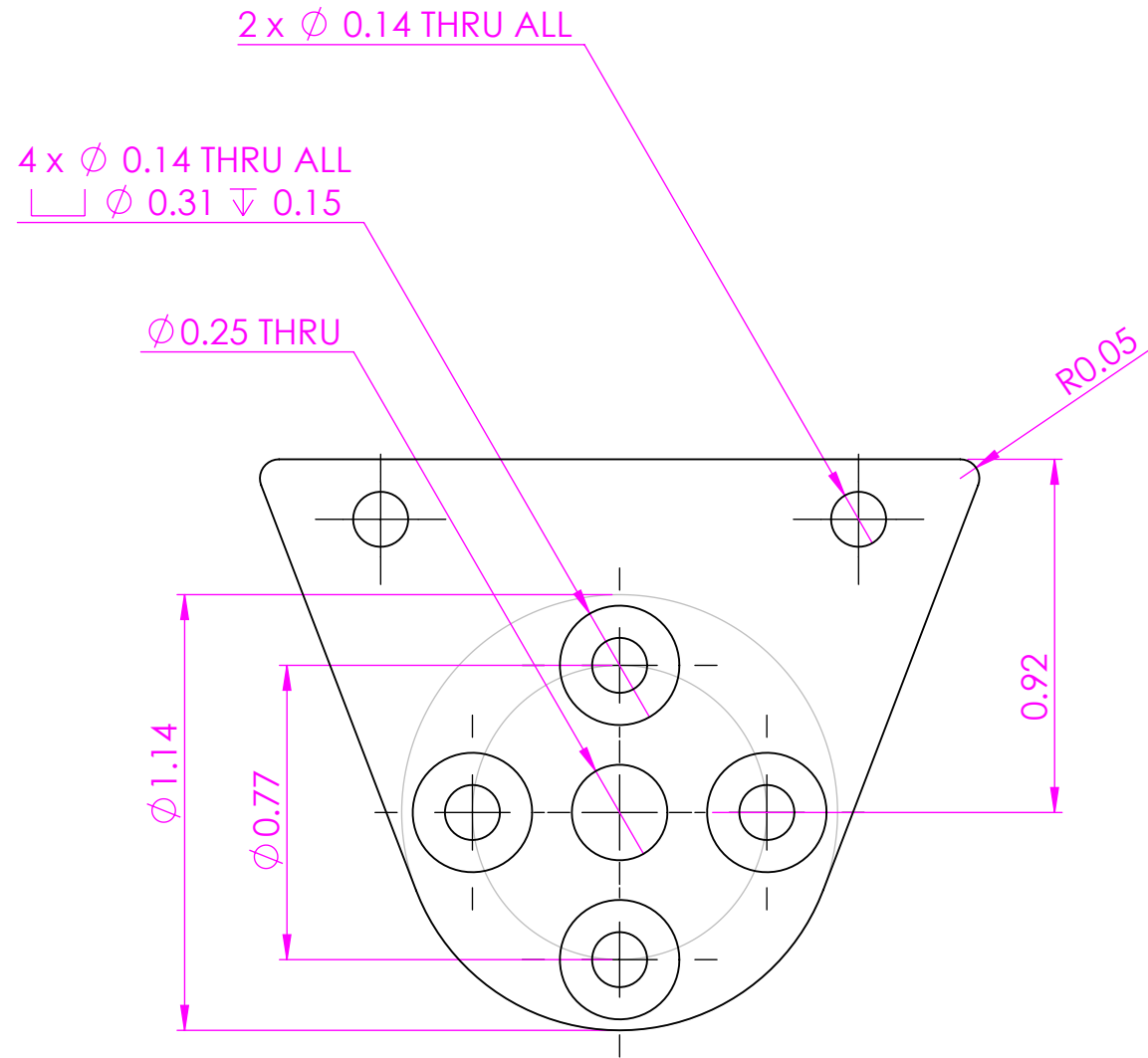

PROPRIETARY AND CONFIDENTIAL
 THE INFORMATION CONTAINED IN THIS
 DRAWING IS THE SOLE PROPERTY OF
 OPENAG, INC. ANY REPRODUCTION
 IN PART OR AS A WHOLE WITHOUT
 THE WRITTEN PERMISSION OF
 OPENAG, INC IS PROHIBITED.

		UNLESS OTHERWISE SPECIFIED:		NAME	DATE	tim savas	
		DIMENSIONS ARE IN INCHES		DRAWN		TITLE:	
		TOLERANCES:		CHECKED		tilt_bracket	
		ANGULAR: MACH \pm 0.5 BEND \pm 1		ENG APPR.			
		TWO PLACE DECIMAL \pm 0.06		MFG APPR.			
		THREE PLACE DECIMAL \pm 0.005		Q.A.			
		MATERIAL		COMMENTS:			
		polycarbonate					
NEXT ASSY	USED ON	FINISH				SIZE	DWG. NO.
APPLICATION		DO NOT SCALE DRAWING				B	
						REV	1
						SCALE: 2:1	WEIGHT:
						SHEET 1 OF 1	

4

3

2

1