

4

3

2

1

2 x ϕ 0.14 THRU ALL
 ϕ 0.28 ∇ 0.14

ϕ 0.26 THRU

R0.10

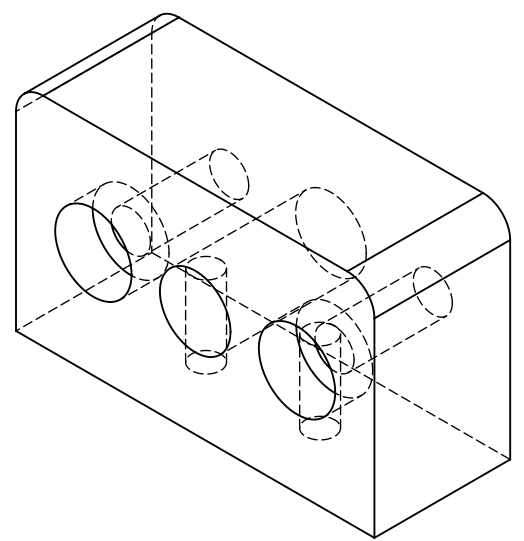
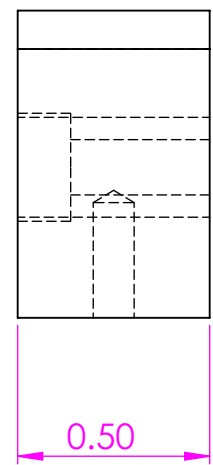
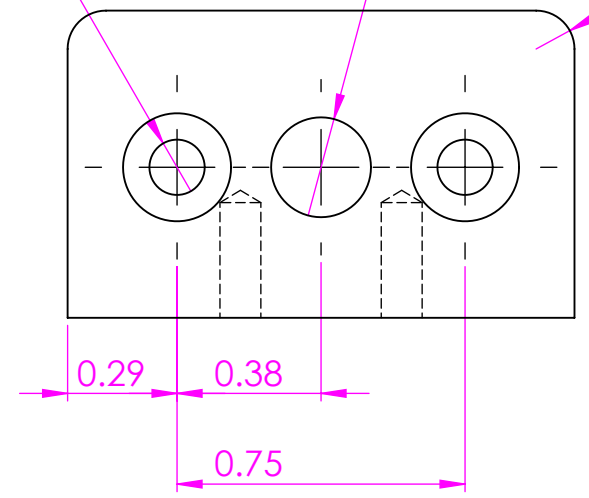

2 x ϕ 0.11 ∇ 0.30

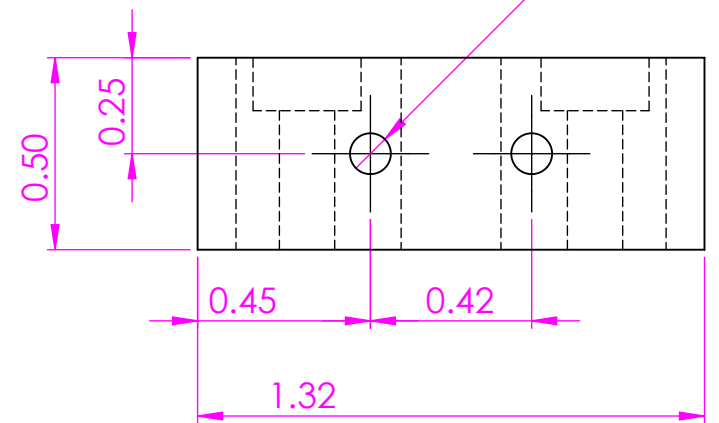

PROPRIETARY AND CONFIDENTIAL
THE INFORMATION CONTAINED IN THIS
DRAWING IS THE SOLE PROPERTY OF
OPENAG, INC. ANY REPRODUCTION
IN PART OR AS A WHOLE WITHOUT
THE WRITTEN PERMISSION OF
OPENAG, INC IS PROHIBITED.

		UNLESS OTHERWISE SPECIFIED:		NAME	DATE	tim savas	
		DIMENSIONS ARE IN INCHES TOLERANCES: ANGULAR: MACH \pm 0.5 BEND \pm 1 TWO PLACE DECIMAL \pm 0.06 THREE PLACE DECIMAL \pm 0.005		DRAWN		TITLE: backlash_mount	
		MATERIAL polycarbonate		CHECKED		SIZE DWG. NO. REV B	
		FINISH		ENG APPR.		WEIGHT: SHEET 1 OF 1	
NEXT ASSY	USED ON			MFG APPR.			
APPLICATION		DO NOT SCALE DRAWING		Q.A.			
				COMMENTS:			

4

3

2

1

B

B

A

A