

4 x ϕ 0.32 THRU ALL
 \square ϕ 0.53 ∇ 0.31

ϕ 0.39 THRU ALL
 \square ϕ 0.63 ∇ 0.38

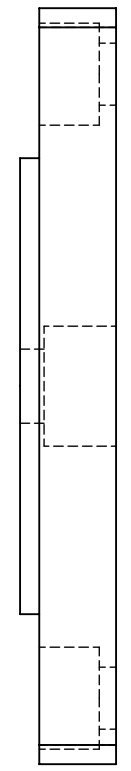
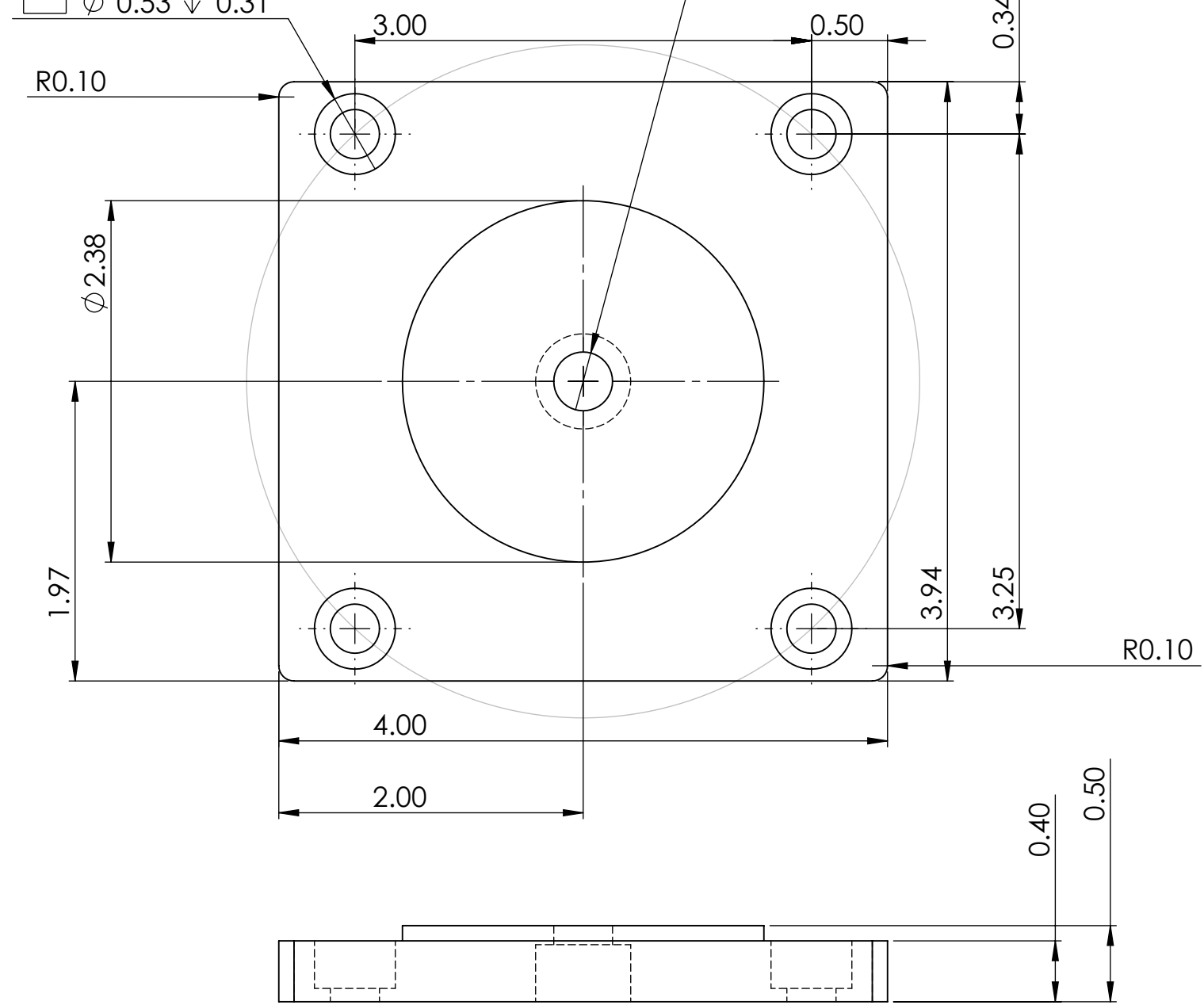

PROPRIETARY AND CONFIDENTIAL
 THE INFORMATION CONTAINED IN THIS
 DRAWING IS THE SOLE PROPERTY OF
 OPENAG, INC. ANY REPRODUCTION
 IN PART OR AS A WHOLE WITHOUT
 THE WRITTEN PERMISSION OF
 OPENAG, INC IS PROHIBITED.

		UNLESS OTHERWISE SPECIFIED:		NAME	DATE	tim savas		
		DIMENSIONS ARE IN INCHES TOLERANCES: ANGULAR: MACH ±0.5 BEND ±1 TWO PLACE DECIMAL ±0.06 THREE PLACE DECIMAL ±0.005		DRAWN		TITLE:		
				CHECKED		stage		
				ENG APPR.				
				MFG APPR.				
		MATERIAL		Q.A.				
		polycarbonate		COMMENTS:				
NEXT ASSY	USED ON	FINISH				SIZE	DWG. NO.	REV
APPLICATION		DO NOT SCALE DRAWING				B		1
						SCALE: 1:1	WEIGHT:	SHEET 1 OF 1